

1394 4P MALE

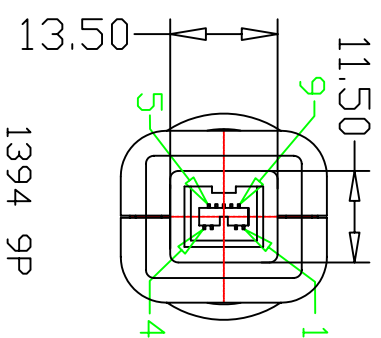

1394 9P

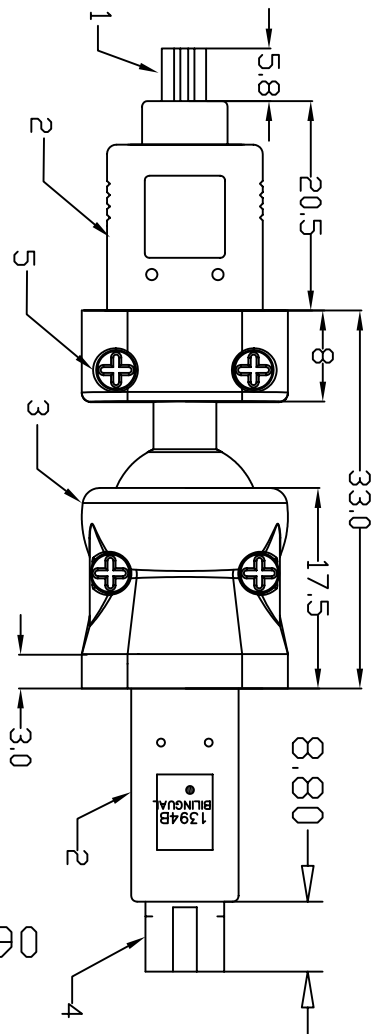
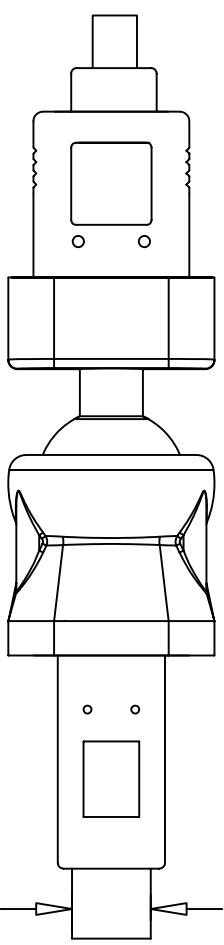

1394 9P

PIN ASSIGNMENT

1394 4P

ELECTRICAL PROPERTIES:

1. 100% OPEN SHORT MIS-WIRE TEST
2. Contact Resistance: 1ohm max
3. Insulation Resistance: 20Mega ohm MIN
4. Hi-Pot: 500V DC/10ms

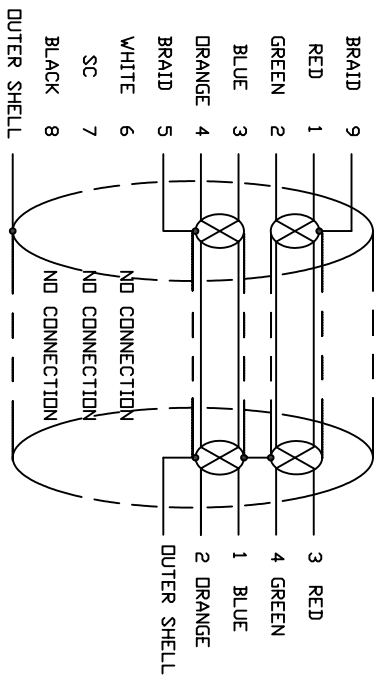

5	4#40 THUMB SCREW	COLOR IN BLACK	4	PCS
4	1394 9P BILINGUAL	BLACK PASTERN CONNECTOR	1	PCS
3	RETRACTABLE MADE OF ABS SHELL		1	PCS
2	P.V.C MOLDING 5SP	COLOR: BLACK		
1	1394 4P MALE	SOLDER MOLDED TYPE	1	PCS
ND.	DESCRIPTION		Q'TY	UNITS
A				

REV.	DESCRIPTION	DATE	APPROVED	SIZE	REV.	FILE NAME:
		06./05./02		A4	A	

UNLESS OTHERWISE SPECIFIED TOLERANCE
 ANG. 0.
 .0
 .00
 NONE
 ERIC: XU
 CHECKED
 APPROVED

SCALE: NONE
 DRAWN: ERIC: XU
 UNIT: MM
 DATE: 06./05./02

DUN CHENG TECH. CORP.
 TEL: 886-2-26739970 FAX: 886-2-26739980
 DRAWN NAME:
 PRODUCT NO.: ??-RO-ADP-1394B-9P

